



Liner Order Form No.2

For Square & Wedge Hopper Markouts

Please read the conditions marked with a ★ and fill out all details and tick boxes where applicable

QUOTE No: _____ PRICE \$ _____ DATE Required: _____

Your Name: _____ PH: _____

Your Client: _____ Order No: _____

Welded Bead: Facing or Type (A) (B) (C)

★ Measure wall height from hook on fixing extrusion to floor, list an exact wall height for welded bead. See back page for bead type & size profiles

Pool Wall Height: _____ mm or use 1 panel Width of 1120mm

A to B Measurement: _____ mm Pool Length: _____ mm

Last Point Before B: _____ Pool Width: _____ mm

T/port Co: _____ P/up Perimeter: _____ mm

All fixing extrusions are in 3m lengths, list quantity of lengths required

Above Water: Retainer EXTRET _____ Capping EXTCAP _____

★ NEW: Retainer for T-Lock EXTW1F _____ T-Lock Black strip EXTW1T _____

Below Water: W/line Male EXTWL3M _____ W/line Female EXTWL3F _____

Please supply one pool liner as per these specifications and conditions:

Signed _____ Date _____

Notes _____

★ All liners are custom made and hence are non-returnable. This form is to order square hopper and wedge floor type liners. Please refer to ABGAL's Inground Liner Manual for more information on measuring these and other types of pools. Fabric is not necessarily Nylex brand but is made to the same high specifications for ABGAL Liners.

STEPS

★ Use opposite end/side corners reference C1, C2, C3, C4 for A-B points when measuring a step or bench.

A - B length _____ Pt. _____ to Pt. _____

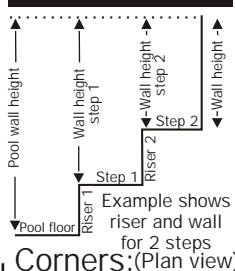

1	_____	_____	_____	_____
2	_____	_____	_____	_____
3	_____	_____	_____	_____
4	_____	_____	_____	_____
5	_____	_____	_____	_____
6	_____	_____	_____	_____
7	_____	_____	_____	_____
8	_____	_____	_____	_____
9	_____	_____	_____	_____
10	_____	_____	_____	_____

Example shows riser and wall for 2 steps

Corners: (Plan view)

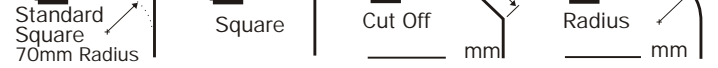

Liner Type: Please circle 1 2 3 4

- A _____ G _____
- B _____ H _____
- B1 _____ J _____
- B2 _____ K _____
- C _____ L _____
- D _____ M _____
- E _____ Q _____
- F _____ R _____

Rounded Hopper
 Length loose _____
 Width loose _____

Fully Rounded Hopper
 Length loose _____
 Width loose _____

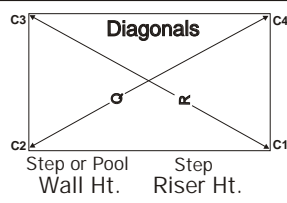

Colour

Dark Blue	<input type="checkbox"/>
Light Blue	<input type="checkbox"/>
Pacific	<input type="checkbox"/>
Antique	<input type="checkbox"/>
Caribbean	<input type="checkbox"/>
Maldive	<input type="checkbox"/>
Coral Sand	<input type="checkbox"/>
Reef Pebble	<input type="checkbox"/>
Mediterranean Marble	<input type="checkbox"/>
Capri	<input type="checkbox"/>
Casablanca	<input type="checkbox"/>
Costa Rica	<input type="checkbox"/>
Reflections	<input type="checkbox"/>
Reflections Tile (beaded)	<input type="checkbox"/>
Mosaic Tile	<input type="checkbox"/>

Please check that the progressive dimensions equal the overall pool length & width. Eg; For pool type 3: E + F + H + M = A.

NOTE: All measurements are taken horizontally, except "C" & "D" which are vertical.

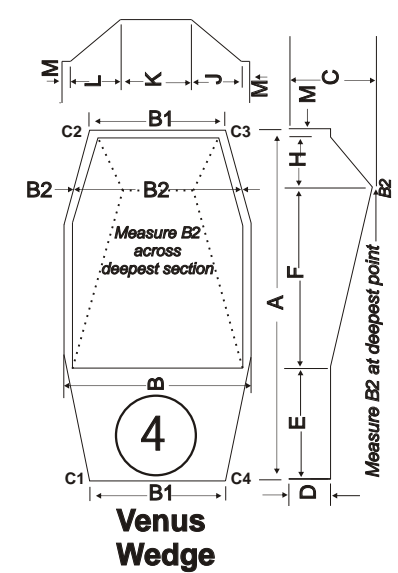
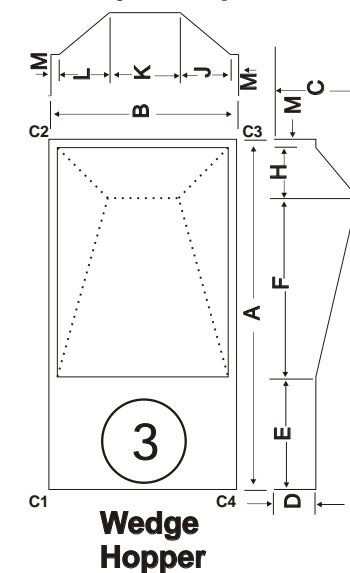
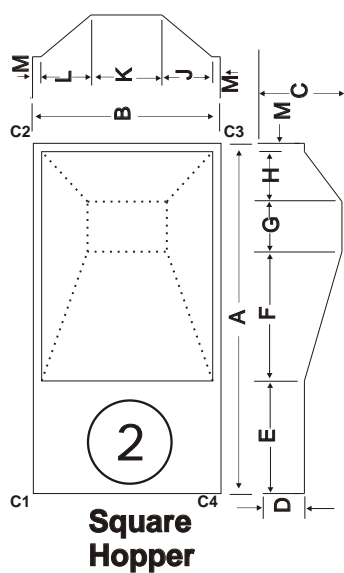
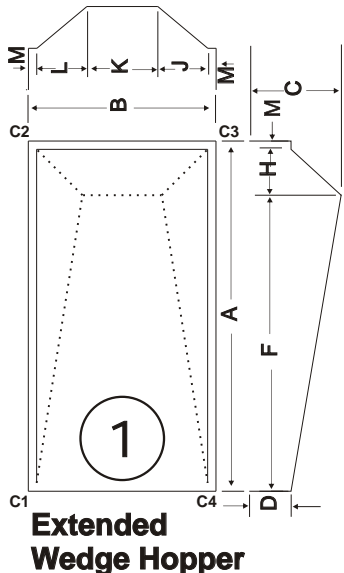

Measuring Instructions for Square & Wedge Hoppers

A "hopper" is a deep end in a vinyl lined pool that has a distinctive geometric shape and flat walls. They are usually either Square (like an inverted pyramid with the top chopped off) or Wedge shaped. The shape of most pools in Australia that have a hopper-type deep end are on the front of this Order Form but kidney and oval pools can have them as well.

If the pool you are measuring has a straight edge step, enter the dimension on the order for. If it has a curved step in it, please use Liner Order Form No.1 in addition to this Order Form. Include on Form No.1 the points in each of the corners of the pool and points around the whole perimeter of the step. This is so we can locate the corners of the pool and the step shape and position.

Please remember to tick which **pool style** you require your liner to be. Simply tick the box next to the appropriate pool style to indicate which hopper style the pool has. You'll see these tick boxes to the left of the diagrams of each of these

How to measure pools with a hopper:

These pools are measured with horizontal and vertical measurements only. The measurements required are listed on Liner Markout Order Form No.2, in the pool shape diagrams. When measuring the depth points "C" and "D", remember to measure both using a plumb bob and from the same level at the top of the pool, otherwise the depth of the hopper will be wrong.

Check that the measurements add up:

After you have measured the pool, add up the progressive measurements along the length of the pool and compare the total to the overall length of the pool. These should equal each other exactly. Eg; Square Hopper: $A = E + F + G + H + M$.

Then, add up the progressive measurements along the width of the pool and compare the total to the overall width of the pool. These should also equal each other exactly. Eg; Square Hopper: $B = M + J + K + L + M$.

If the hopper is "rounded":

If the hopper is rounded and the shape of the deepest section is not clear, add some water to the deep section with a garden hose until it's about 100 - 150mm deep. Then, create a rectangle with opposite sides the same length, using the top of the water as a guide. Measure the overall depth of "C" to the top of the water only.

List the loose measurement of both the length and width of the pool with the tape along the floor through one of the lines of the rectangle. Tick the "Rounded Hopper" box in the measurements screen so the liner will be made to suit a rounded hopper floor.

Check that the pool is square:

Some rectangular pools are not built square and it is important to check that the pool is square before leaving the site. The Abgal Markout Form No.2 uses points R and Q as the diagonal lengths of the rectangle. (See Diagram 14)

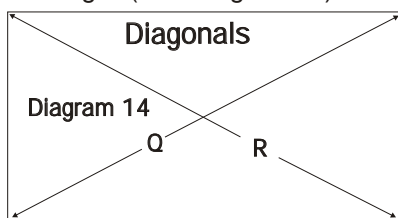

What shape are the corners?

These same types of pool have different corner shapes, the most common being a radius or cut off. Indicate which type you require on the markout sheet and list down the size of the radius or cut off. (See Diagram 15)

If the pool has square corners, the liner is normally made with a 70mm radius. This makes it easier to install but will not sit back against the wall of the pool as firm as when the liner is made dead square. Square corners always require extra installation time to ensure they sit back against the pool wall.

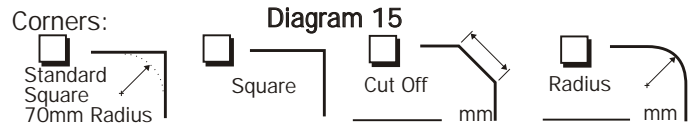

What is bead?

Bead is flexible extrusion welded to the top edge of the liner that is used to fasten the liner in the pool. There are many "kit" type vinyl lined pools that use the bead method of fixing the liner in the pool as it is the easiest and simplest to use.

It is *important* that the wall heights of the pool are very accurate when using bead because there is no room for adjustment. The fit of the liner is totally dependant on the measurements and finished size of the liner. Beaded liners are less commonly used in refurbished pools as these types are often complex shapes and need to be adjusted as they are fitted.

Which bead profile to use?

The best way to work out the size and profile of the bead to have welded to the liner is to match an existing piece from the old liner with Diagram 16.

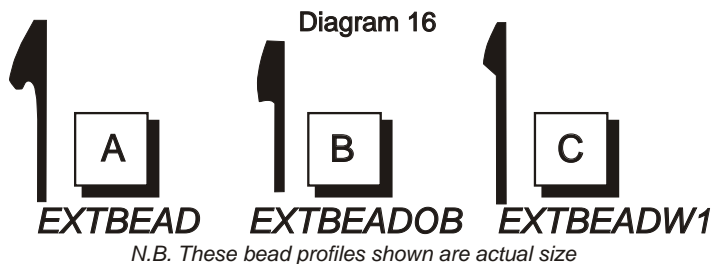

Choose the bead you want by the code A, B or C and write it on the markout sheet.

Bead facing which way?

You need to indicate which way the bead "hook" is facing when you order. Is it facing toward the pool water or away from the pool water? Check the pool and the way the bead faces as it fits into the extrusion on the pool. Then tick the appropriate box on the markout sheet.

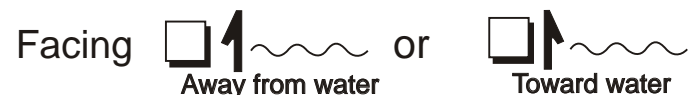

Finally, please remember to fill out all the other relevant details on your markout sheet like "Quote Number", "Liner Colour", "Date Required" etc. **Thank You.**